

ELEVATION "B"

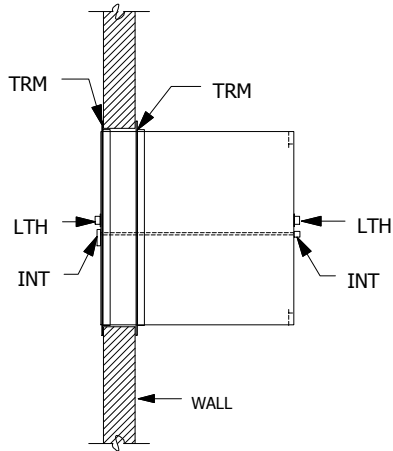

ELEVATION "A"

DOOR NOT SHOWN
TRIM NOT SHOWN

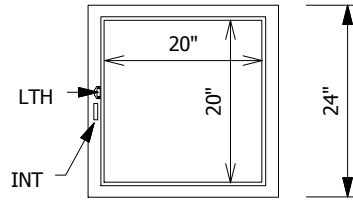

ELEVATION "A"

DOOR SHOWN
TRIM NOT SHOWN

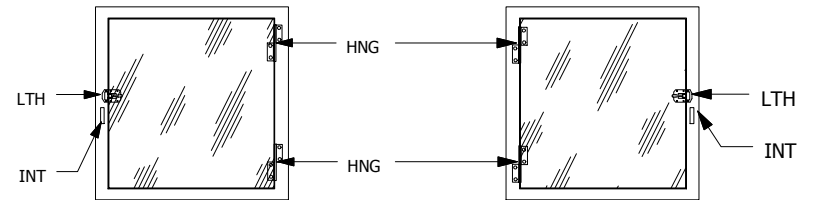

ELEVATION "C"

DOOR SHOWN
TRIM NOT SHOWN

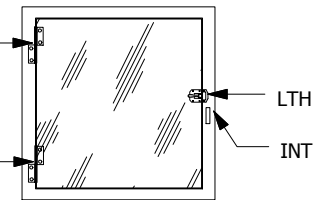

PLAN VIEW

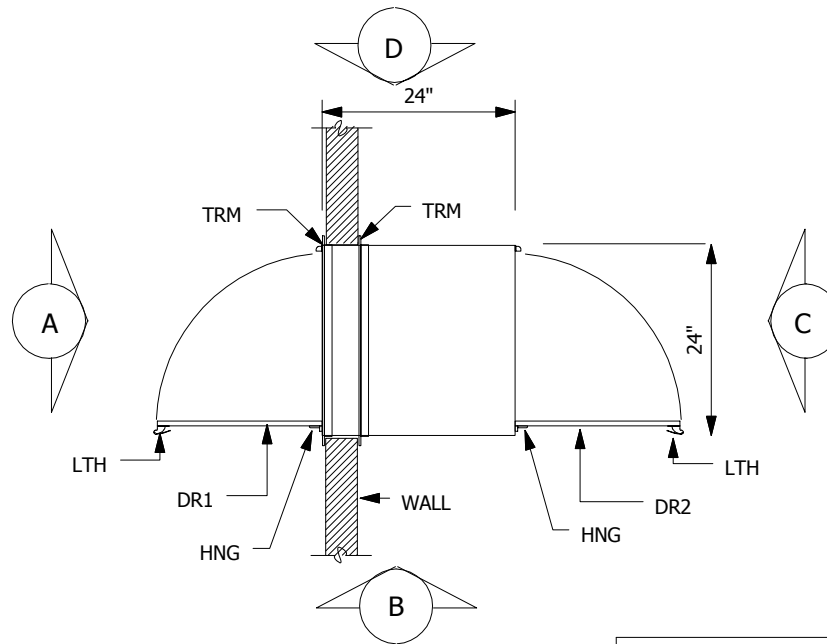

LEGEND

- DR1=CLEAR ACRYLIC DOOR
- DR2=CLEAR ACRYLIC DOOR
- GSK=PEMKO S88W GASKET SEAL
- HNG=STAINLESS STEEL LIFT OFF DOOR HINGE
- INT=POLISHED ALUMINUM INTERLOCK LEVER
- LTH=CHROME PLATED SPRING LOADED DOOR CATCH
- TRM=1.5" x 1.5" 304 STAINLESS STEEL ANGLE

NOTES:

1. PASS THRU IS CONSTRUCTED OF A DOUBLE WALL COLD ROLL STEEL WITH A WHITE POWDER COATED FINISH
2. TRIM ANGLE IS SHIPPED LOOSE TO ALLOW FLEXIBILITY OF INSTALLATION
3. THE PASS THRU HAS MECHANICAL INTERLOCKS
5. WALL CUT OUT IS 5/8" LARGER THAN THE OUTSIDE DIMENSIONS OF THE PASS THRU
6. THE I.D. DIMENSIONS SHOWN ON THE DRAWING REFLECT THE NET DOOR OPENING.
7. ALL SEAMS HAVE A CONTINUOUS WELD



PO Box 427
Rancho Cucamonga, CA 91729-0427
Voice: (800) 913-0054
Fax: (909) 483-1801

Drw# SPDP242424

Title: PAINTED STEEL PASS THRU

Sheet:

Project name: