

ELEVATION "B"

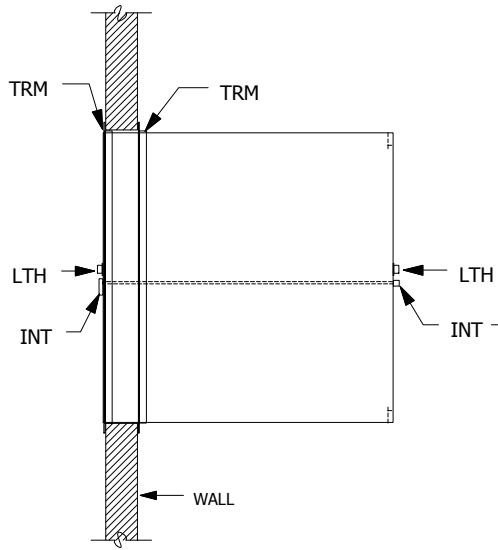

ELEVATION "A"

DOOR NOT SHOWN
TRIM NOT SHOWN

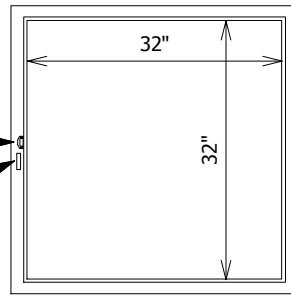

ELEVATION "A"

DOOR SHOWN
TRIM NOT SHOWN

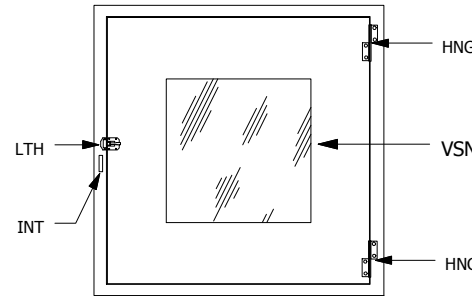

ELEVATION "C"

DOOR SHOWN
TRIM NOT SHOWN

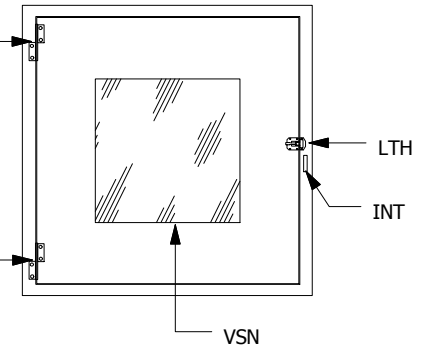

PLAN VIEW

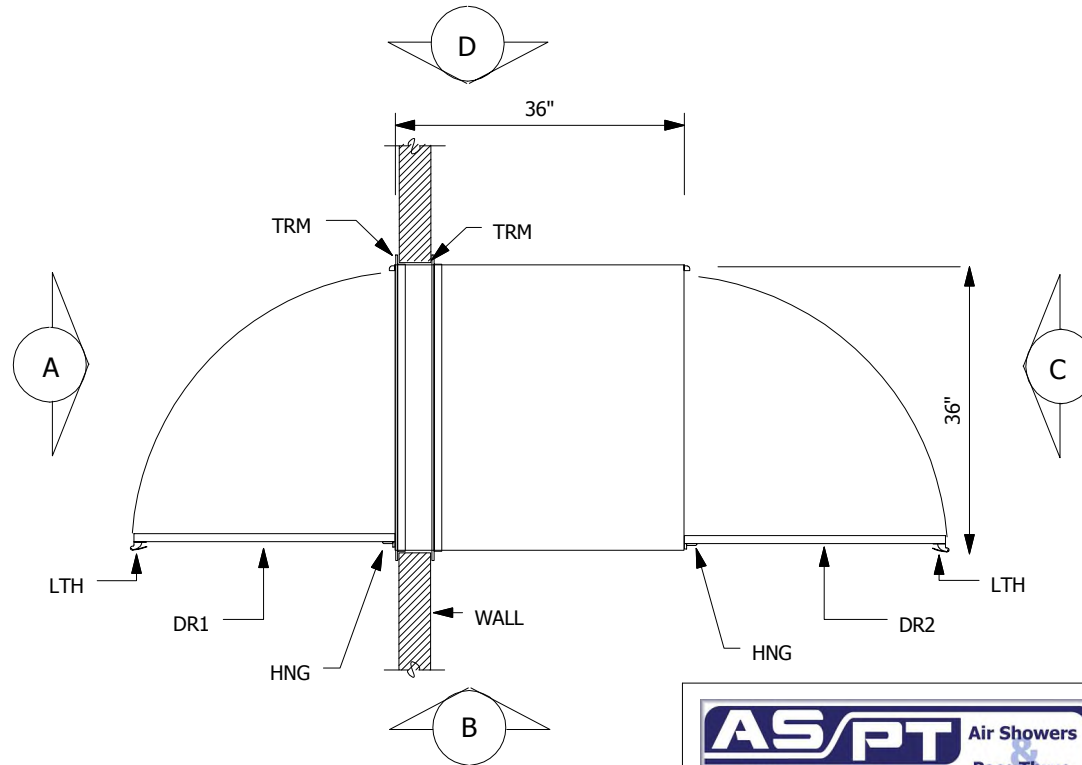

LEGEND

- DR1=304 STAINLESS STEEL DOOR FRAME
- DR2=304 STAINLESS STEEL DOOR FRAME
- GSK=PEMCO S88W GASKET SEAL
- HNG=STAINLESS STEEL LIFT OFF HINGE
- INT=POLISHED ALUMINUM INTERLOCK LEVER
- LTH=CHROME PLATED SPRING LOADED DOOR CATCH
- TRM=1.5" x 1.5" 304 STAINLESS STEEL ANGLE
- VSN=18" x 18" x 0.25" CLEAR ACRYLIC VISION PANEL

NOTES:

1. PASS THRU IS CONSTRUCTED OF A SINGLE WALL 304 STAINLESS STEEL WITH A #4 BRUSHED FINISH
2. TRIM ANGLE IS SHIPPED LOOSE TO ALLOW FLEXIBILITY OF INSTALLATION
3. THE PASS THRU HAS MECHANICAL INTERLOCKS
5. WALL CUT OUT IS 5/8" LARGER THAN THE OUTSIDE DIMENSIONS OF THE PASS THRU
6. THE I.D. DIMENSIONS SHOWN ON THE DRAWING REFLECT THE NET DOOR OPENING.
7. ALL SEAMS HAVE A CONTINUOUS WELD AND ARE GROUND SMOOTH TO MATCH THE #4 FINISH



PO Box 427
Rancho Cucamonga, CA 91729-0427
Voice: (800) 913-0054
Fax: (909) 483-1801

Drw# SWS363636

Title: STAINLESS STEEL PASS THRU

Sheet:

Project name: