

PLAN VIEW

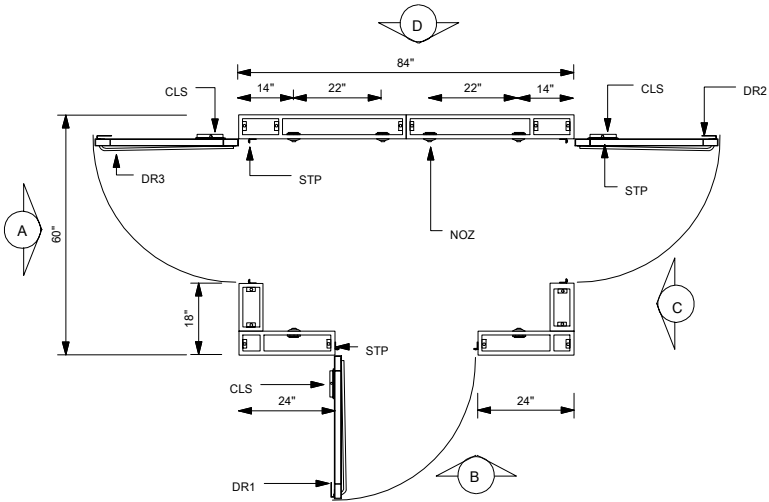

CEILING VIEW

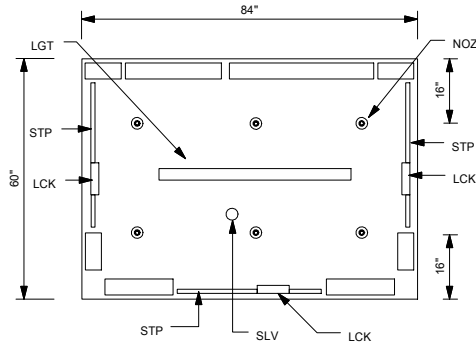

ROOF VIEW

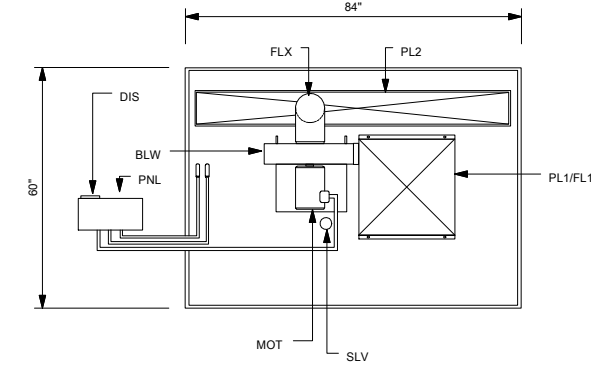

ELEVATION "C"

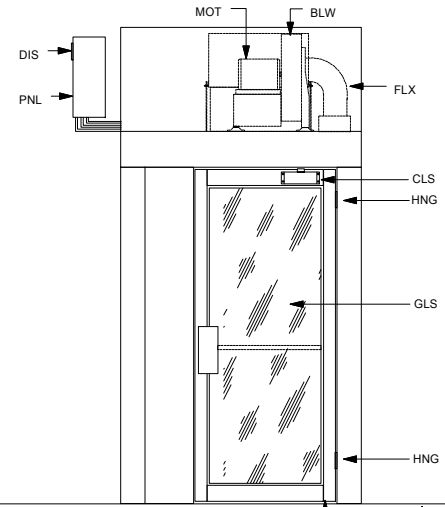

ELEVATION "D"
CUTAWAY VIEW

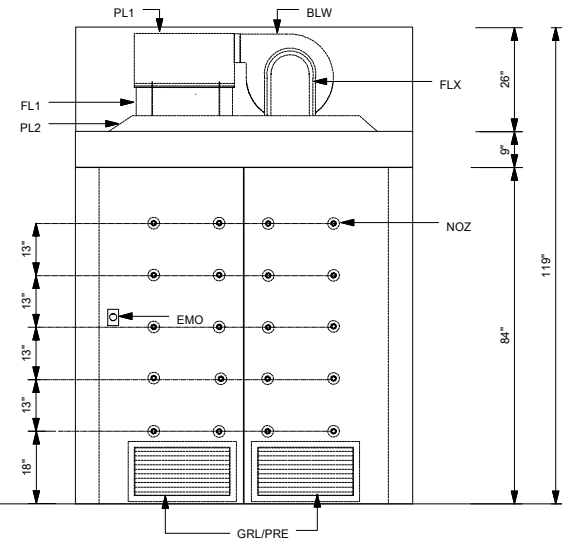

ELEVATION "B"

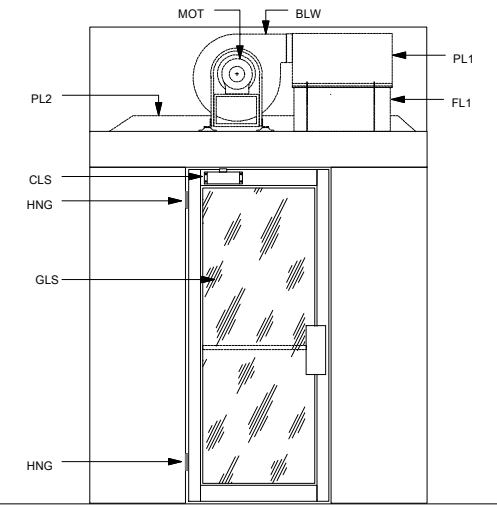

LEGEND
 BLW=5HP DIRECT DRIVE PADDLE WHEEL BLOWER 1550 CFM @ 6" S.P.
 CLS=COMMERCIAL DUTY DOOR CLOSER
 DIS=NON-FUSED DISCONNECT SWITCH FOR CONTROL PANEL
 EMO=EMERGENCY STOP SWITCH
 DR1=CLEAR ANODIZED ALUMINUM FRAME DOOR (ENTRY END)
 DR2=CLEAR ANODIZED ALUMINUM FRAME DOOR (EXIT END)
 DR3=CLEAR ANODIZED ALUMINUM FRAME DOOR (ENTRY OR EXIT)
 FL1=99.99% @ .3 MICRON HEPA FILTER FOR RETURN AIR
 FLX=8" DIAMETER FLEX CONNECTION FOR RETURN AIR
 GLS=.25" THICK CLEAR TEMPERED GLASS
 GRL=RETURN AIR GRILLE
 HNG=4.5" NICKEL PLATED DOOR HINGE
 LCK=24VDC MAGNETIC DOOR LOCK
 LGT=LED LIGHT FIXTURE
 MOT=5HP DIRECT DRIVE OPEN DRIP PROOF MOTOR 3500 RPM
 NOZ=.875" DIAMETER WHITE PLASTIC AIR NOZZLE (30 IN WALLS & 6 IN CEILING)
 PL1=HEPA FILTER PLENUM 0.60" THICK ALUMINUM CONSTRUCTION
 PL2=RETURN AIR PLENUM 0.60" THICK ALUMINUM CONSTRUCTION
 PNL=NEMA 1 ENLOSURE CONTROL PANEL
 PRE=MERV 7 PANEL FILTER
 SLV=SLEEVED PENETRATION THROUGH ROOF FOR INSTALLTION OF SPRINKER
 STP=PEMKO #285CPK DOOR SEALS
 SWP=PEMKO #307AV DOOR SWEEP

Notes:

1. The control panel is connected to the air shower with 8' of seal tight flex.
2. The air shower is shipped knock down into (6) walls, (1) roof and (3) doors.
3. The air shower is supplied with a sleeved penetration through the roofsection for installation of a sprinkler head. Sprinkler is by others.
4. The air shower does not have a floor. It uses the existing floor.



PO Box 427
 Rancho Cucamonga, CA 91729-0427
 Voice: (800) 913-0054
 Fax: (909) 483-1801

Drw# SD6084TT	Title: MODEL "SD" AIR SHOWER	
Sheet:	Project:	Date: