

PLAN VIEW

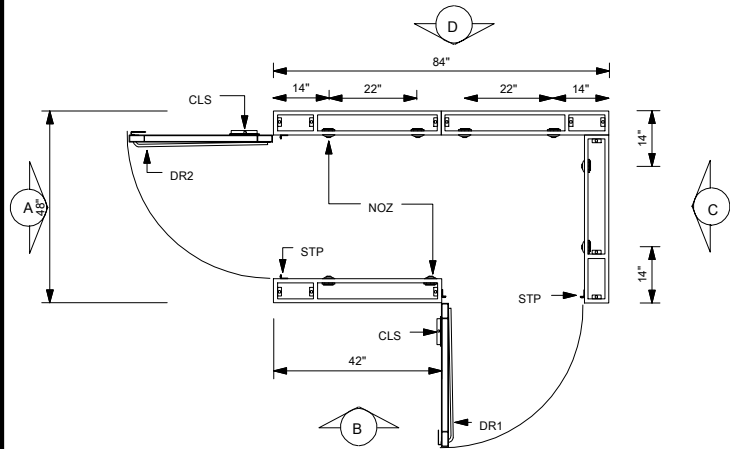

CEILING VIEW

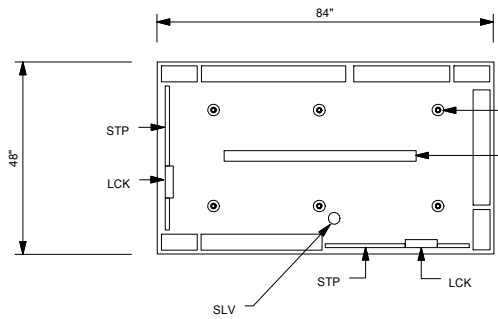

ROOF VIEW

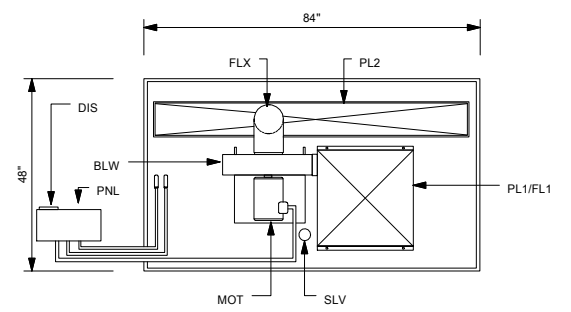

ELEVATION "A"

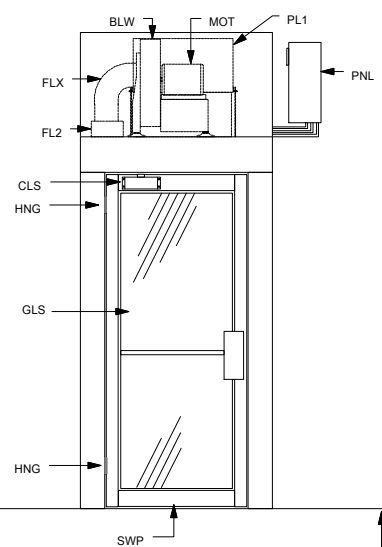

ELEVATION "D"

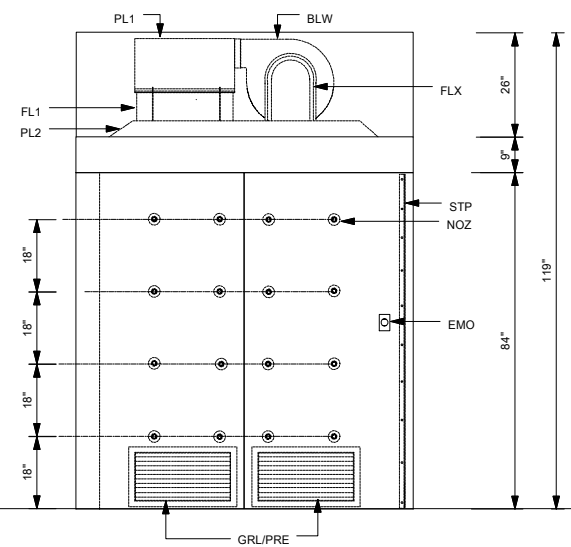

ELEVATION "B"

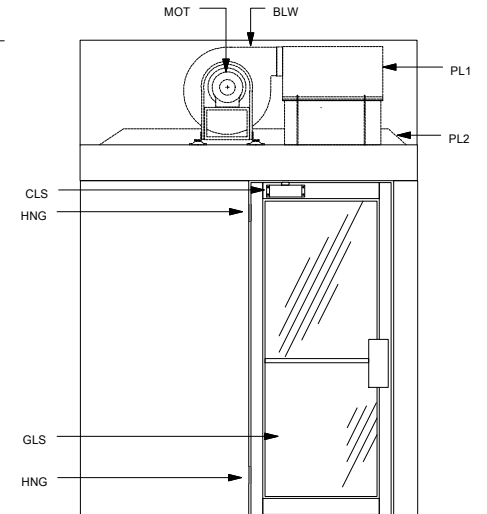

LEGEND

- BLW=5HP DIRECT DRIVE PADDLE WHEEL BLOWER 1550 CFM @ 6" S.P.
- CLS=COMMERCIAL DUTY DOOR CLOSER
- DIS=NON-FUSED DISCONNECT SWITCH FOR CONTROL PANEL
- EMO=EMERGENCY STOP SWITCH
- DR1=CLEAR ANODIZED ALUMINUM FRAME DOOR ( ENTRY END)
- DR2=CLEAR ANODIZED ALUMINUM FRAME DOOR ( EXIT END)
- FL1=99.99% @ .3 MICRON HEPA FILTER
- FLX=8" DIAMETER FLEX CONNECTION FOR RETURN AIR
- GLS=0.25" THICK CLEAR TEMPERED GLASS
- GRL=RETURN AIR GRILLE
- HNG=4.5" NICKEL PLATED BUTT HINGE
- LGT=LED LIGHT FIXTURE
- MOT=5HP DIRECT DRIVE OPEN DRIP PROOF MOTOR 3500 RPM
- NOZ=0.875" DIAMETER WHITE PLASTIC AIR NOZZLE ( 30 IN WALLS & 6 IN CEILING)
- PL1=HEPA FILTER PLENUM 0.60" THICK ALUMINUM CONSTRUCTION
- PL2=RETURN AIR PLENUM 0.60" THICK ALUMINUM CONSTRUCTION
- PNL=NEMA 1 ENLOSURE CONTROL PANEL
- PRE=MERV 7 PANEL FILTER
- SLV=SLEEVED PENETRATION THROUGH ROOF FOR INSTALLTION OF SPRINKER
- STP=PEMKO #285CPK DOOR SEALS
- SWP=PEMKO #307AV DOOR SWEEP

EXISTING FINISHED FLOOR

Notes:

1. The control panel is connected to the air shower with 8' of seal tight flex.
2. The air shower is shipped knock down into (4) walls, (1) roof and (2) doors.
3. The air shower is supplied with a sleeved penetration through the roofsection for installation of a sprinkler head. Sprinkler is by others.
4. The air shower does not have a floor. It uses the existing floor.



PO Box 427  
 Rancho Cucamonga, CA 91729-0427  
 Voice: (800) 913-0054  
 Fax: (909) 483-1801

Drw# SD4884LA

Title: MODEL "SD" AIR SHOWER

Sheet:

Project:

Date: